

1

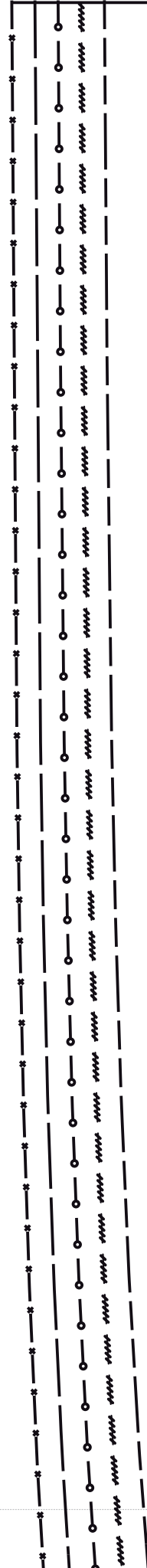

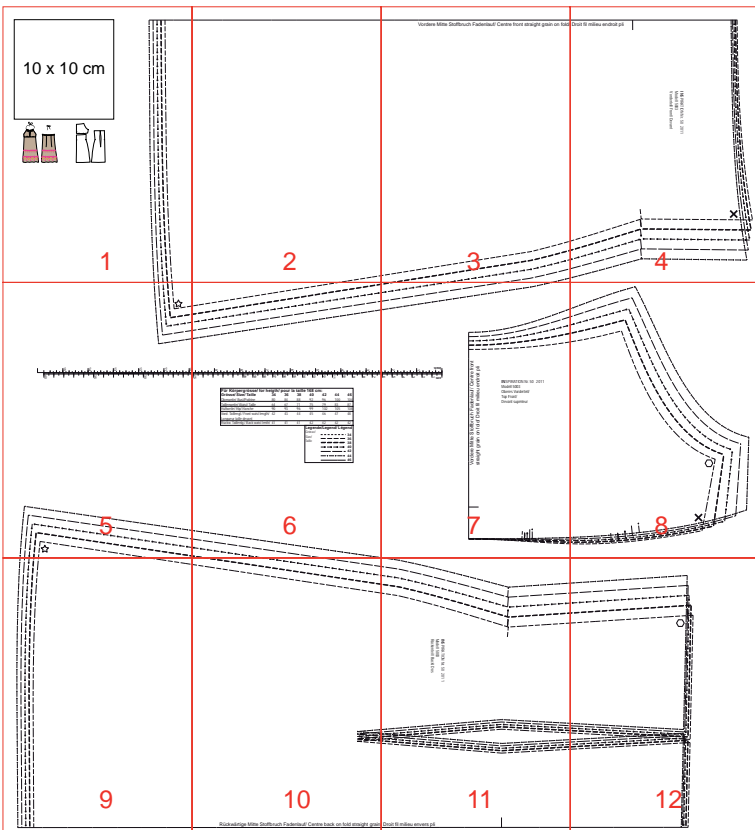

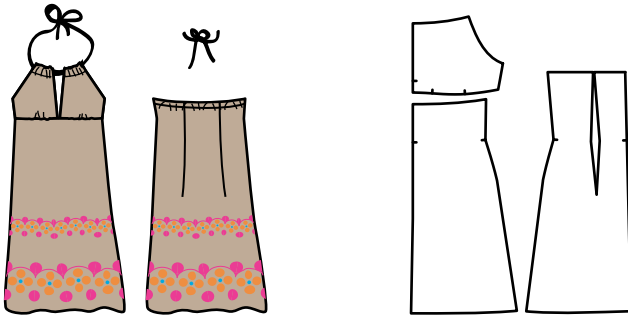
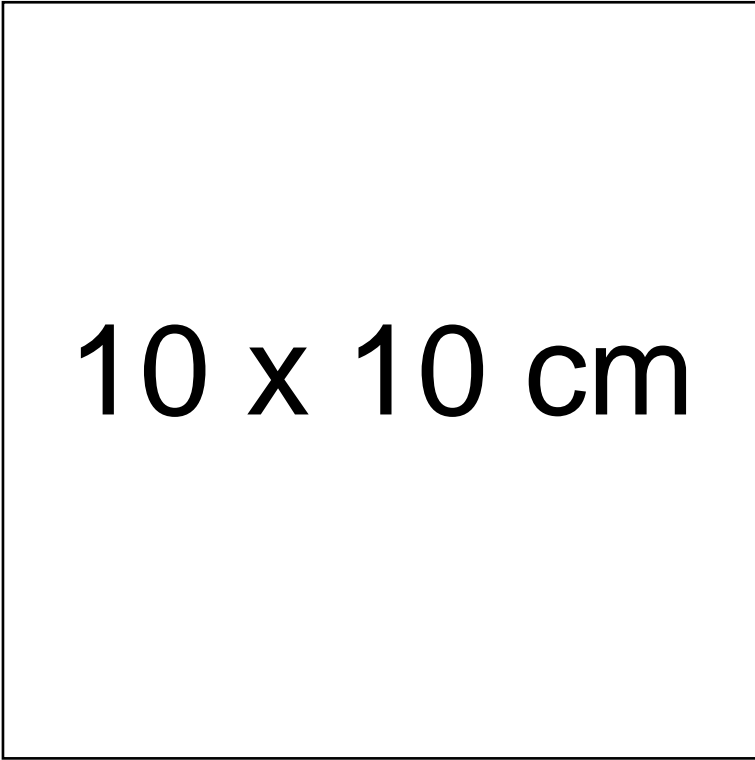
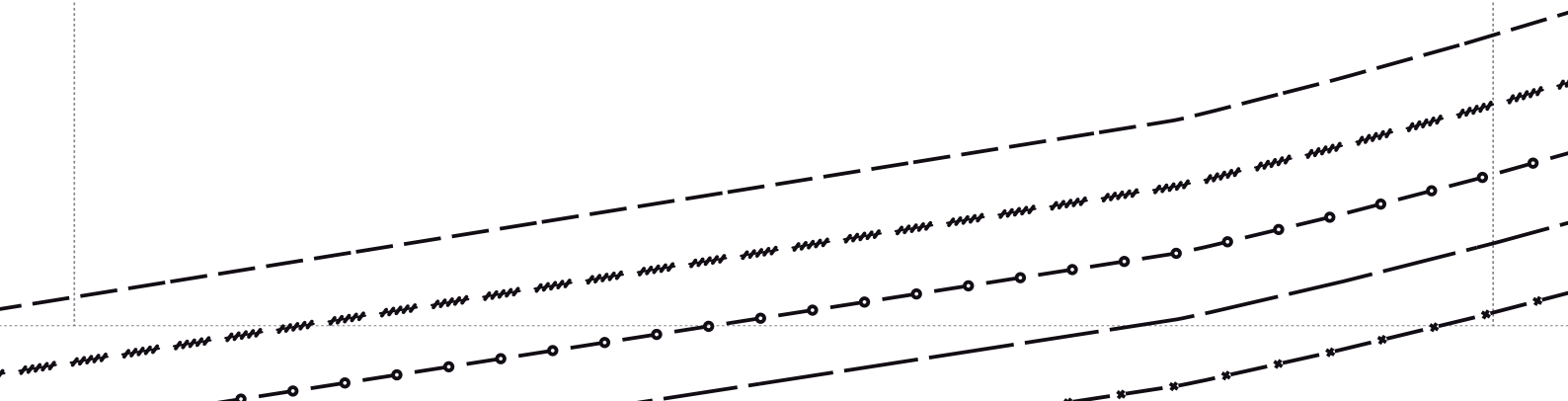

5

4+1-Aktion: Zu Ihrem inspirations-
Abo schenken wir Ihnen eine Gratis-
Ausgabe!



Als Prämie erhalte ich ein Heft gratis, also statt der
4 Ausgaben eines Abonnements erhalte ich 5.

► ICH ABONNIERE DIE INSPIRATION FÜR 1 JAHR (4 AUSGABEN)

Land Schweiz 29 CHF

Europa 24 EURO

alle Preise inkl. MwSt. und Porto

Sprache Deutsch

Englisch

Französisch

Niederländisch

Name

Geburtsjahr

Strasse, Nr.

Plz, Ort

Telefon

E-Mail

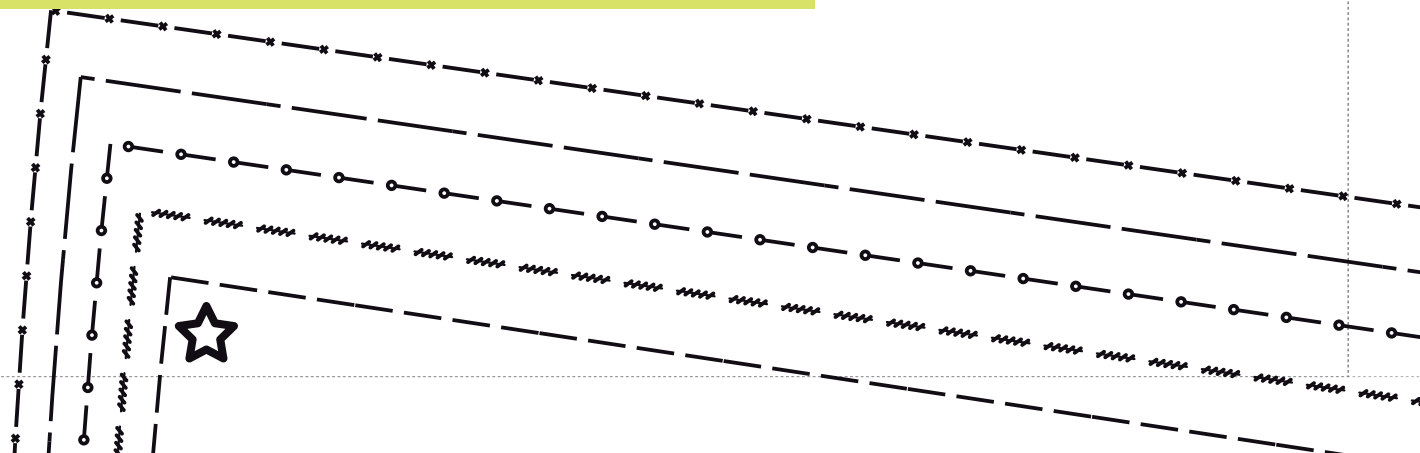
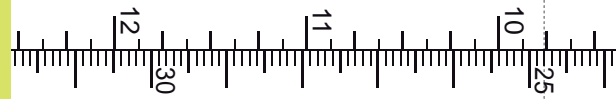

6



Für Körpergröße/ for height/ pour la taille 168 cm:

Größe/ Size/ Taille	34	36	38	40	42	44	46
Oberweite/ Bust/Poitrine	80	84	88	92	96	100	104
Taillenweite/ Waist/ Taille	64	67	71	75	79	83	87
Hüftweite/ Hip/ Hanche	90	93	96	99	102	105	108
Vord. Taillengl./ Front waist length/ Longueur taille devant	42	43	44	45	46	47	48
Rückw. Taillengl./ Back waist length/	41	41	41	42	42	42	42

Legende/Legend/ Légend

Größe/	-----	34
Size/	_____	36
Taille	~~~~~	38
	—○—○—○—○	40
	-----	42
	—*—*—*—*	44
	—————	46

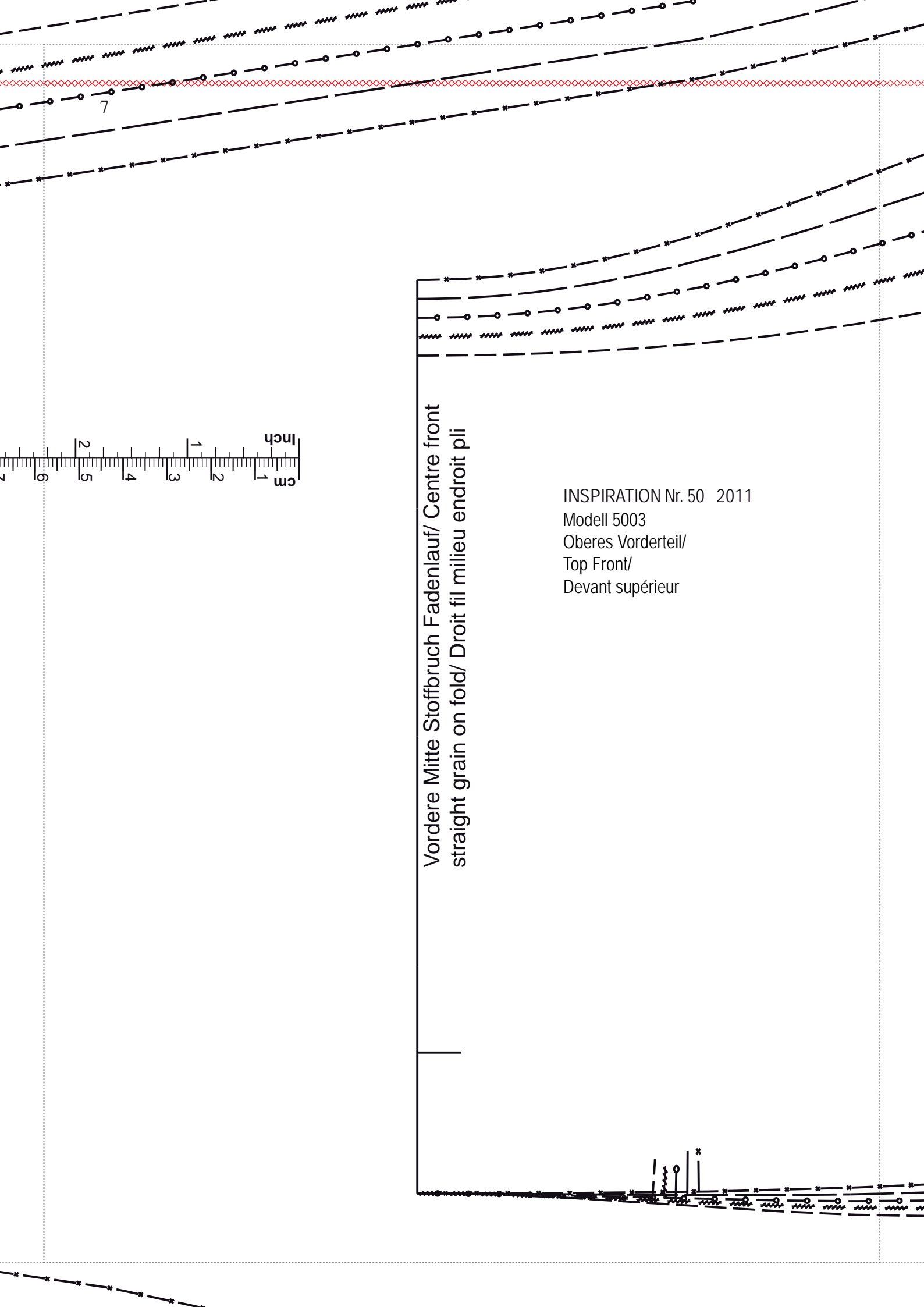

7



Vordere Mitte Stoffbruch Fadenlauf/ Centre front
straight grain on fold/ Droit fil milieu endroit pli

INSPIRATION Nr. 50 2011
Modell 5003
Oberes Vorderteil/
Top Front/
Devant supérieur

8

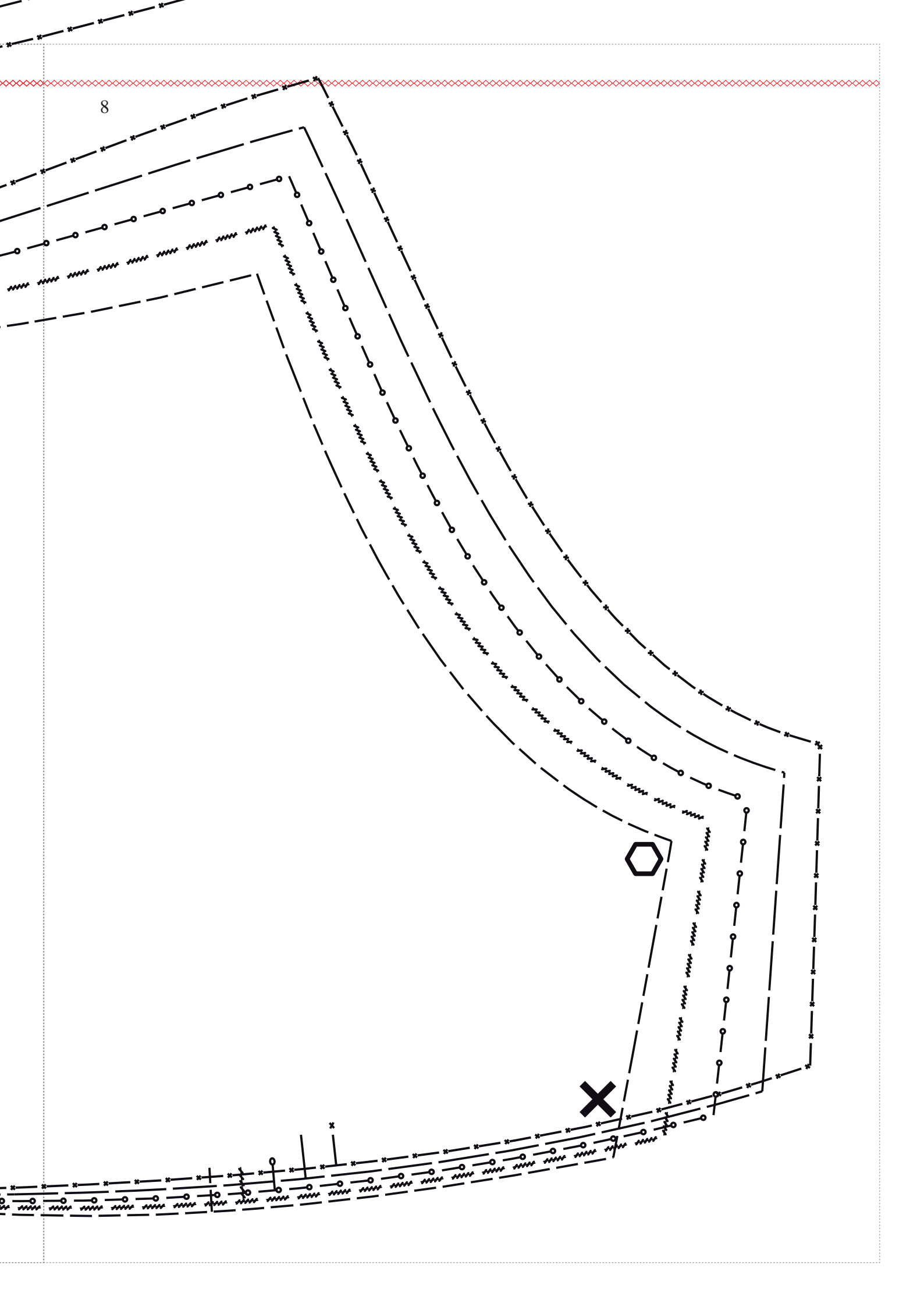



A large rectangular area for drawing or writing, bounded by a solid black line on the left and bottom, and a dashed black line on the top and right. A horizontal red dashed line with a diamond pattern runs across the top of the page. On the left side, there are two vertical dashed lines. The inner dashed line contains a series of small circles, and the outer dashed line contains a series of small asterisks. The top right corner features a dashed line with a zigzag pattern.

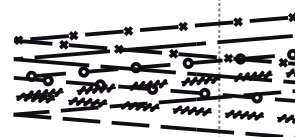
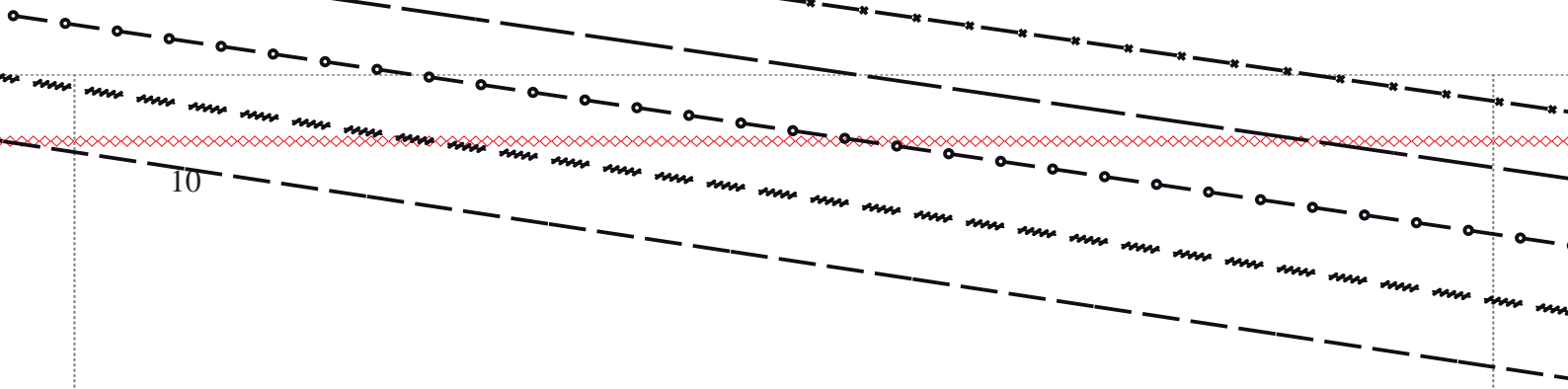

Rückwärtige Mitte Stoffbruch Fadenlauf/ Centre back on fold straight grain/ Droit

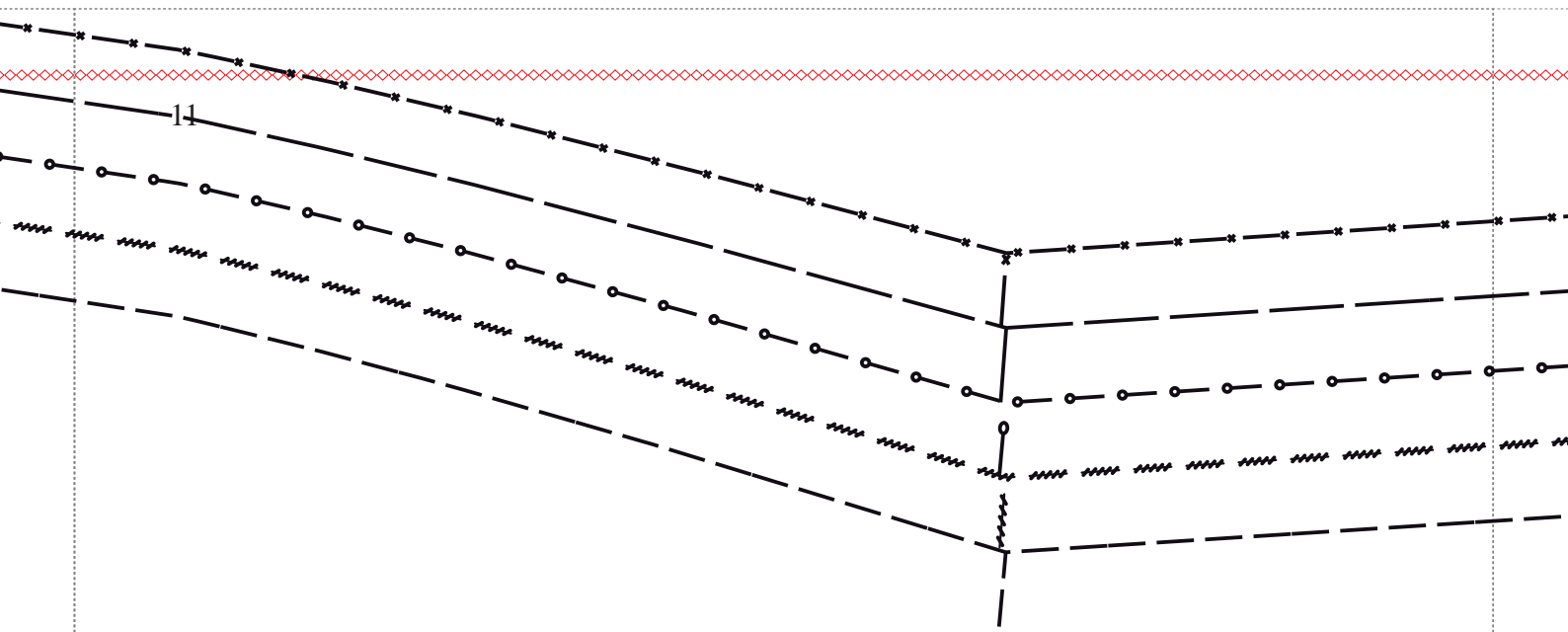

11

INSPIRATION Nr. 50 2011
Modell 5003
Rückenteil/ Back/ Dos

